

- Cost-benefit optimized system
- System with integrated shock absorber
- Easy installation because of pre-assembled parts
- System passable on both sides (intermediate brackets passable with carabiner)
- Available in different lengths
- Tested in accordance with EN 795

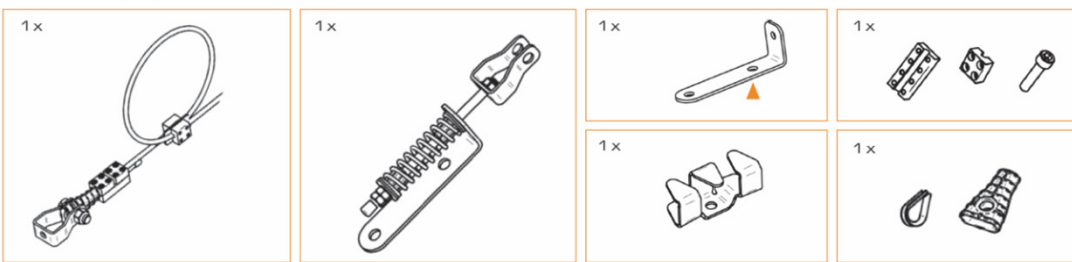

Universal and simple: The Innotech-Lifeline-Kit is for nearly all applications, eg: industry roofs, standard roofs and cladding. It is compatible with all Innotech elements.



The Innotech Lifeline Kit is very easy to transport. It consists of an 8mm stainless steel cable which is fastened with two end units. The connections to the system occur via carabiners.

Due to the constant spring biased and the shock absorbers the maximum power inlet to the substructure in the corners and end units is max. 10kN

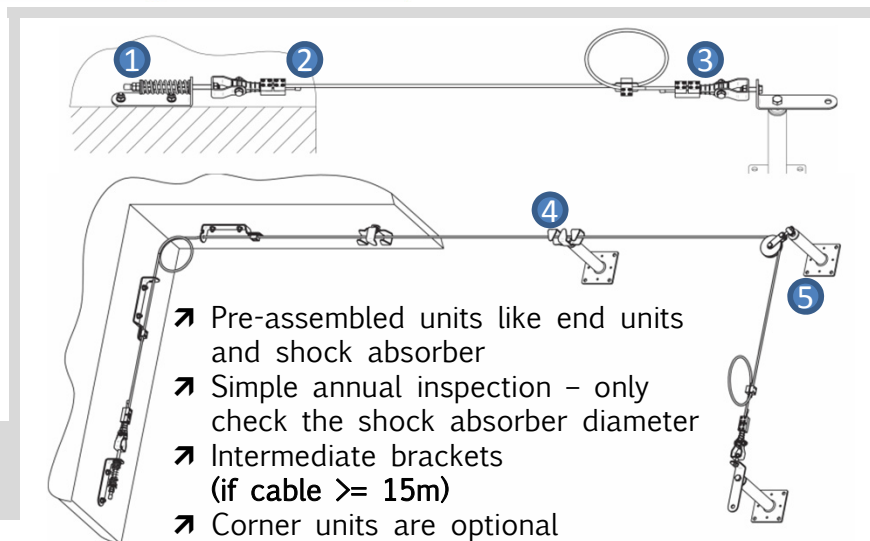
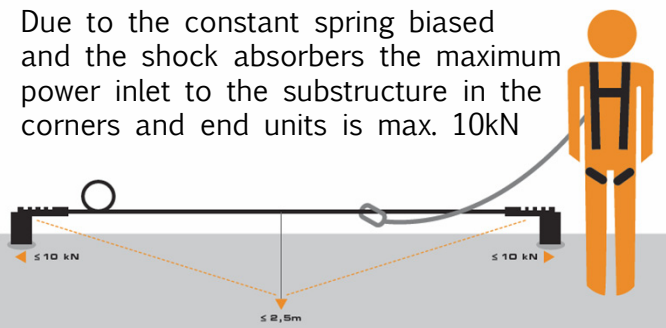

Lifeline Kit Components



Endlock:
Pre-assembled with constant spring-biased

Clamp:
To fasten the cable at the endlock

Shock Absorber:
Cable loop pre-assembled

Intermediate Bracket: Passable if cable is $\geq 15\text{m}$

Corner Unit:
Optional, range of corner-unit is adjustable